



DX SUBMERSIBLE DRAINAGE & WASTE WATER PUMPS

50 Hz

Flygt



ITT Industries
Engineered for life

MOVING OR REMOVING WATER – CLEAN, USED OR WORSE

Presenting the DX range from Flygt. Compact, high-performance, submersible pumps with pump body and motor casing in stainless steel. Available with a vortex or channel type impeller. In all, there are eight sizes offering a wide range of applications:

- from 0.55 to 0.75 kW, 1-phase, and 0.55 to 1.1 kW, 3-phase versions

- emptying of sewage collection tanks, civil drainage and used water in general
- drainage of underpasses and yards, tanks and reservoirs, ditches and trenches
- transfer of dirty water
- transfer of clean and contaminated waters
- emergency drainage in case of flooding
- transfer of groundwater

Features

- Dry motor
- Continuous duty with liquid at 35°C when the pump is completely submerged
- Twin seal system with lower mechanical seal in Silicone Carbide and upper lip seal in nitrile rubber

- Float switch in compliance with European standards
- Power supply cable in neoprene type HO7RN-F

Featuring the DX 35-5 and DXV 35-5

- Discharge 1 1/2" BSP
- 35 mm passage of suspended solids
- Impeller in fibreglass-reinforced nylon

Featuring the DX 50-7 ... 15, and the DXV 50-7 ... 15:

- Discharge 2" BSP (convertible to flanged version with optional accessory)
- 50 mm passage of suspended solids
- Twin channel or vortex impeller in stainless steel

- 1 Lifting handle, fibreglass-reinforced nylon
- 2 Testing hole for injecting compressed air to check the hermetic seal of the motor gaskets
- 3 Cable holder. The float switch cable can be fixed at various heights to start the pump at the fluid level required
- 4 Capacitor
- 5 Dry motor, with class F windings and built-in motor protection (for single-phase versions)

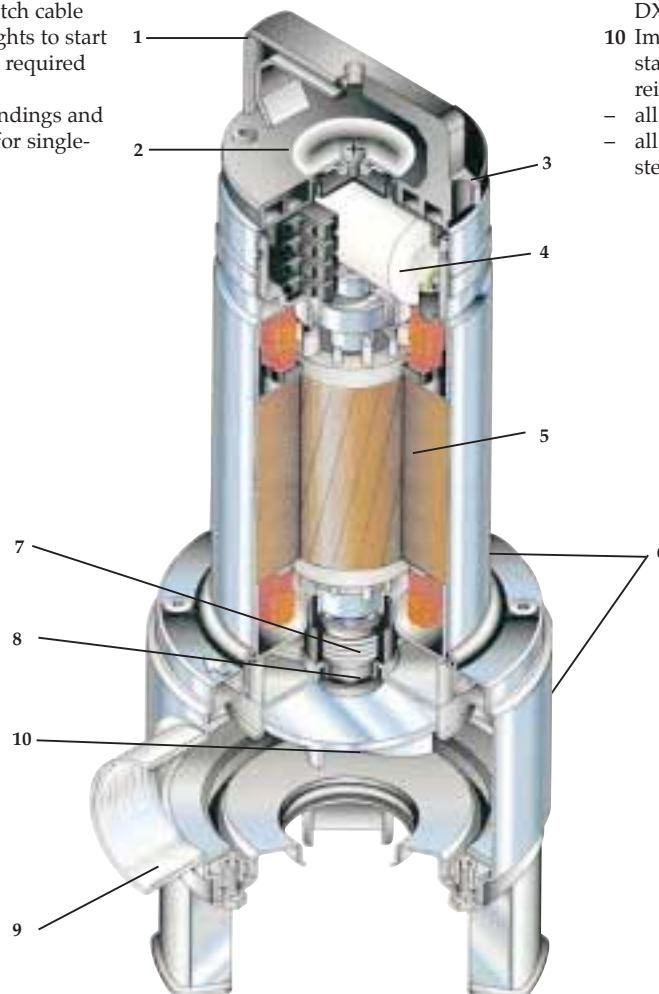

- 6 Pump body and motor casing in stainless steel AISI 304
- 7 Sealing system
- 8 Shaft in stainless steel AISI 304
- 9 Delivery port from 2" (50 mm) except DX(V) 35-5 with 1 1/2" ports (35 mm)
- 10 Impeller, vortex or channel type, in stainless steel AISI 304 (or fibreglass-reinforced nylon in the DXV 35-5)
 - all elastomers in nitrile rubber (NBR)
 - all screws and washers in stainless steel AISI 304

DX 35-5, 50-7, 50-11, 50-15

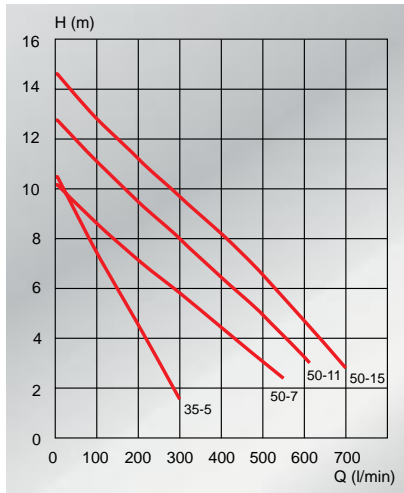

DXV 35-5, 50-7, 50-11, 50-15

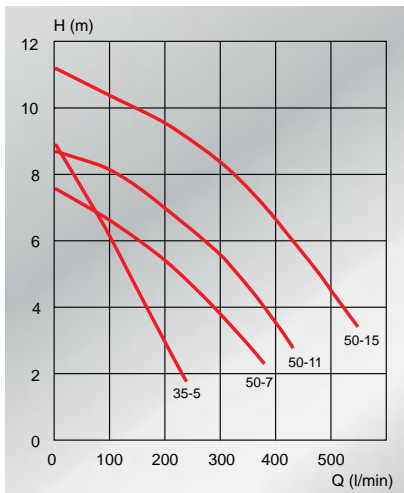

	DX 35-5	DX 50-7	DX 50-11	DX 50-15
Rated output kW	0.55	0.75	1.1	1.5
Max head m	10.5	10.25	12.8	14.5
Max flow l/min	300	540	615	700
1-phase	X	X	X	-
3-phase	X	X	X	X
Rated current				
1-phase A	3.3	5.1	7.1	-
3-phase A	1.35	2.1	2.8	3.7
Discharge conn:	1 1/2"	2"	2"	2"
Voltage	1-phase 230V, 3-phase 400V			
Max temp of pumped liquid	35°C			
Cable HO7RN-7	10 m			
Float switch for 1-phase	optional			

	DXV 35-5	DXV 50-7	DXV 50-11	DXV 50-15
Rated output kW	0.55	0.75	1.1	1.5
Max head m	9	7.7	9	11.2
Max flow l/min	300	540	615	700
1-phase	X	X	X	-
3-phase	X	X	X	X
Rated current				
1-phase A	3.3	5.2	6.2	-
3-phase A	1.3	2.1	2.5	3.4
Discharge conn:	1 1/2"	2"	2"	2"
Voltage	1-phase 230V, 3-phase 400V			
Max temp of pumped liquid	35°C			
Cable HO7RN-7	10 m			
Float switch for 1-phase	optional			

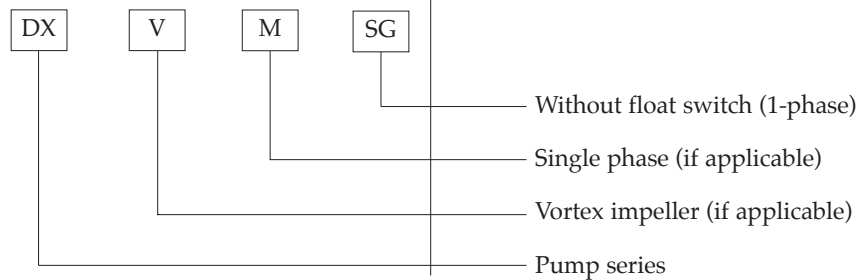

PUMP DIMENSIONS AND WEIGHTS

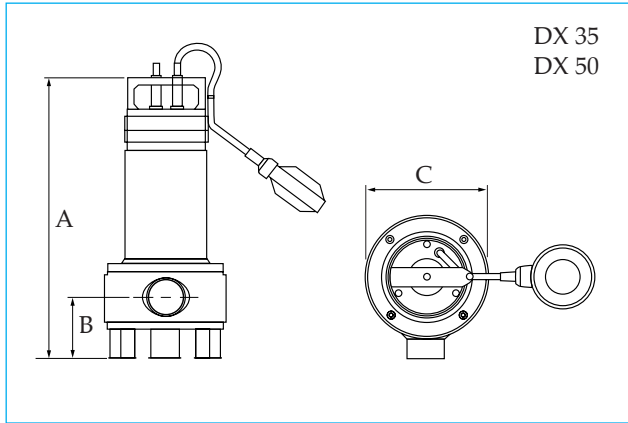

Pump type	Dimensions in mm			Outlet Ø	Weight kg
	A	B	C		
DX 35-5	386	88	193	G 1 1/4"	10
DXV 35-5	386	88	193	G 1 1/4"	10
DX 50-7	433	111.5	198	G 2"	13.4
DXV 50-7	433	111.5	198	G 2"	13.4
DX 50-11	453	111.5	198	G 2"	15.1
DXV 50-11	453	111.5	198	G 2"	15.1
DX 50-15	473	111.5	195	G 2"	14.4
DXV 50-15	473	111.5	195	G 2"	14.4

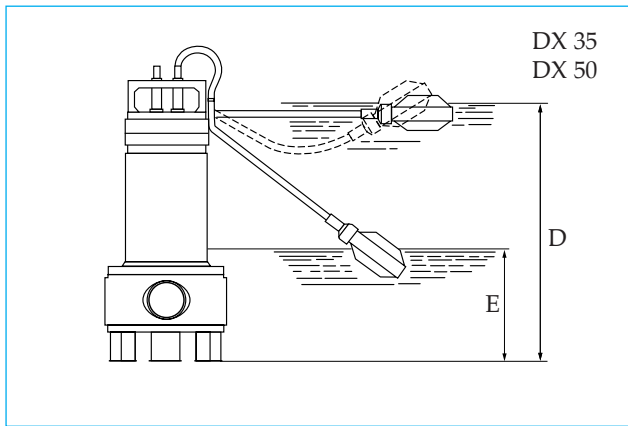

Pump type	Dimensions in mm	
	D	E
DX 35-5	370	150
DXV 35-5	370	150
DX 50-7	375	150
DXV 50-7	375	150
DX 50-11	395	150
DXV 50-11	395	150
DX 50-15	430	150
DXV 50-15	430	150

