

# HL225M Dri-Prime® Pump

The Godwin Dri-Prime HL225M pump offers flow rates to 3660 USGPM and has the capability of discharge pressures to 164 psi.

The HL225M is able to automatically prime to 28' of suction lift from dry. Automatic or manual starting/stopping available through integral mounted control panel or optional wireless-remote access.

High discharge pressure, dry-running, and portability make the HL225M the perfect choice for mining, industrial and emergency fire backup applications.



## Features and Benefits

- Simple maintenance normally limited to checking fluid levels and filters.
- Dri-Prime (continuously operated Venturi air ejector priming device) requiring no periodic adjustment or control. Optional automatic on-off control available on the priming system.
- Dry-running high pressure liquid bath mechanical seal with high abrasion resistant solid silicon carbide faces.
- Close-coupled centrifugal pump with Dri-Prime system coupled to a diesel engine or electric motor.
- All cast iron construction (stainless steel construction option available) with cast steel impeller.
- Also available in a critically silenced unit which reduces noise levels to less than 70dBA at 30'.
- Standard engine Caterpillar C9 (T3 Flex). Also available with John Deere 6090HFC94 (IT4).

## Specifications

Suction connection	10" 150# ANSI B16.5
Delivery connection	8" 150# ANSI B16.5
Max capacity	3660 USGPM †
Max solids handling	2.6"
Max Impeller diameter	17.3"
Max operating temp	176°F*
Max working pressure	164 psi
Max suction pressure	87 psi
Max casing pressure	246 psi
Max operating speed	2000 rpm

\* Please contact our office for applications in excess of 176°F.

† Larger diameter pipes may be required for maximum flows.

## Performance Curve

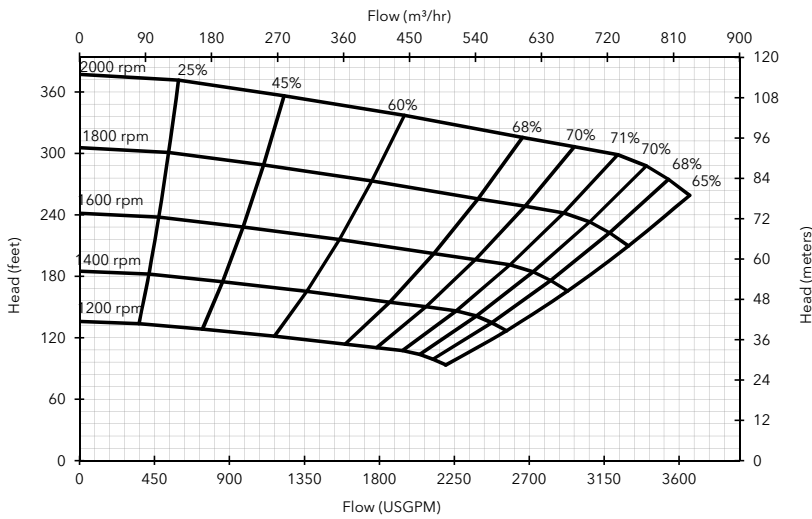

### Engine option 1

Caterpillar C9 (T3 Flex), 300 HP @ 2000 rpm

Impeller diameter 17.3"

Pump speed 2000 rpm

#### Suction Lift Table

Total Suction Head (feet)	Total Delivery Head (feet)				
	245	286	306	326	347
	Output (USGPM)				
10	3694	3278	2691	1957	1223
15	3669	3180	2495	1585	978
20	2691	2568	2348	1565	783
25	2079	1908	1712	1223	-

Fuel capacity: 200 US Gal

Max Fuel consumption @ 2000 rpm: 15.4 US Gal/hr

Max Fuel consumption @ 1800 rpm: 15.1 US Gal/hr

Weight (Dry): 8,810 lbs

Weight (Wet): 10,250 lbs

Dimensions: (L) 152" x (W) 62" x (H) 97"

Performance data provided in tables is based on water tests at sea level and 20°C ambient. All information is approximate and for general guidance only. Please contact the factory or office for further details.

## Materials

Pump casing & suction cover	Cast iron BS EN 1561 - 1997
Wearplates	Cast iron BS EN 1561 - 1997
Pump Shaft	Carbon steel BS 970 - 1991 817M40T
Impeller	Cast Steel BS3100 A5 Hardness to 200 HB Brinell
Non-return valve body	Cast Iron
Mechanical seal	Silicon carbide face; Viton elastomers; Stainless steel body

### Engine option 2

John Deere 6090HFC94 (IT4), 304 HP @ 2000 rpm

Impeller diameter 17.3"

Pump speed 2000 rpm

#### Suction Lift Table

Total Suction Head (feet)	Total Delivery Head (feet)				
	245	286	306	326	347
	Output (USGPM)				
10	3694	3278	2691	1957	1223
15	3669	3180	2495	1585	978
20	2691	2568	2348	1565	783
25	2079	1908	1712	1223	-

Fuel capacity: 200 US Gal

Max Fuel consumption @ 2000 rpm: 15.1 US Gal/hr

Max Fuel consumption @ 1800 rpm: 14.7 US Gal/hr

Weight (Dry): 9,390 lbs

Weight (Wet): 10,830 lbs

Dimensions: (L) 152" x (W) 62" x (H) 97"

Performance data provided in tables is based on water tests at sea level and 20°C ambient. All information is approximate and for general guidance only. Please contact the factory or office for further details.

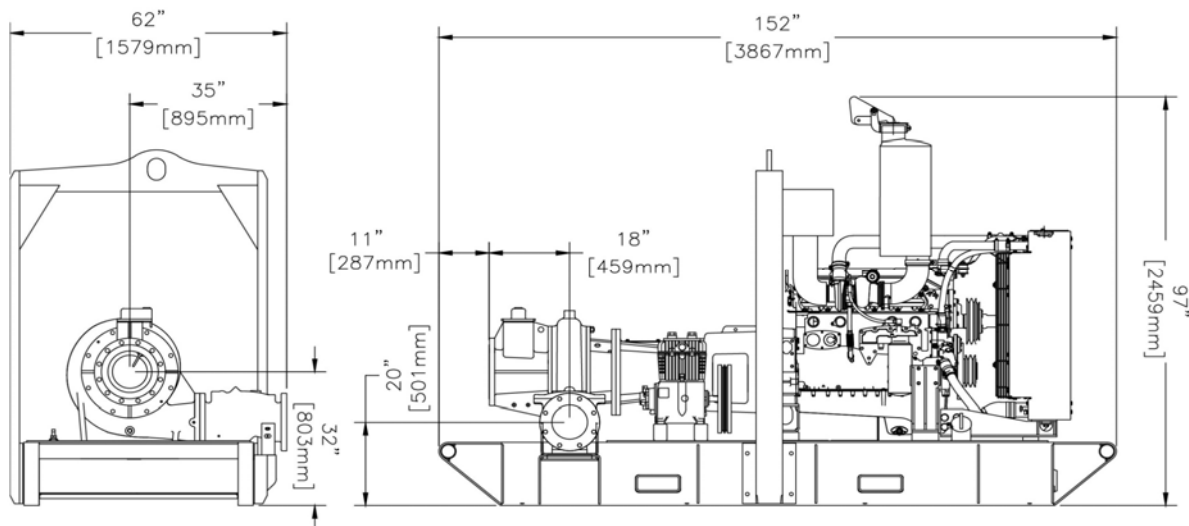

84 Floodgate Road  
Bridgeport, NJ 08014 USA  
(856) 467-3636 . Fax (856) 467-4841  
Email: sales@godwinpumps.com

Reference number : 95-1113-3000  
Date of issue : February 26, 2014  
Issue : 3

[www.godwinpumps.com](http://www.godwinpumps.com)