



# Product catalogue

Submersible drainage & waste water pump DX, 50 Hz



Flygt



ITT Industries  
Engineered for life



## Introduction

The DX range is a compact high performance range of submersible pumps with pump body and motor casing in stainless steel. Dry motor with class F insulation and twin seal system.

Delivery: up to 700 l/min

Head: up to 14.5 m

## Applications

- Emptying of sewage collection tanks, civil drainage and waste water in general
- Drainage of underpasses and yards, tanks and reservoirs, ditches and trenches
- Transfer of dirty water
- Transfer of clean and contaminated water
- Emergency drainage in case of flooding
- Transfer of groundwater

## Product identity

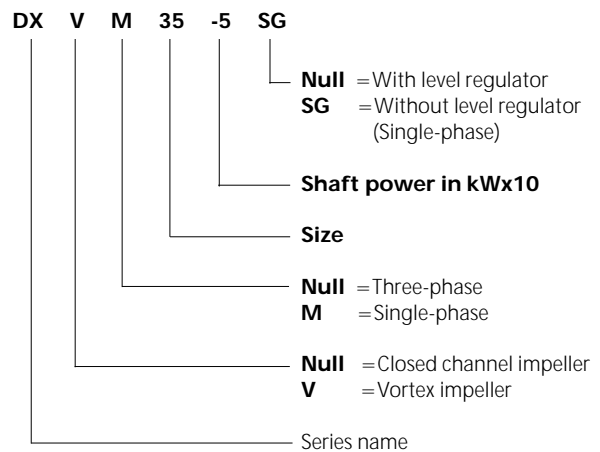



## DX

### Product

Submersible pump for a variety of drainage and waste water applications.

### Process data

Liquid temperature max 35°C

Max size of suspended solids:

DX 35 mm  
DXV 50 mm

### Motor data

Dry motor for submersible duty. Continuously duty when fully submerged. Single phase motor has built in capacitor (except DX 50-11, which has the capacitor in a built in control box on the cable).

Frequency 50 Hz  
Insulation class F (155°C)  
Protection class IP68  
Immersion depth max 5 m

### Cable

H07RN-F 10 m

### Control

Single-phase Built in level regulator  
Three-phase To be provided

### Design

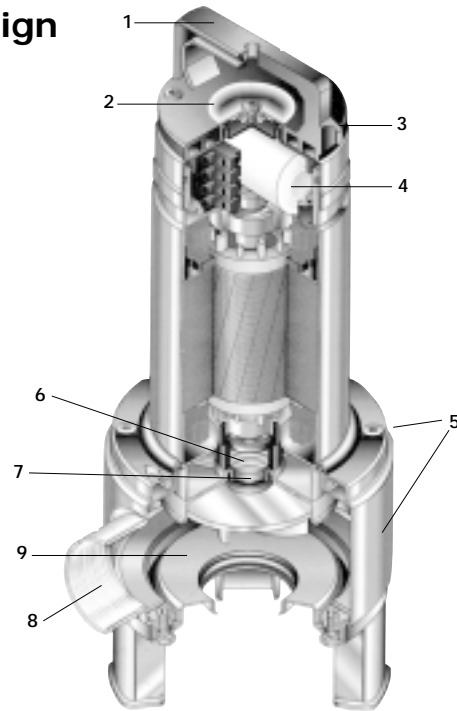

1. Lifting handle, fibreglass-reinforced nylon
2. Testing hole for injecting compressed air to check the hermetic seal of the motor gaskets
3. Cable holder. The float switch cable can be fixed at various heights to start the pump at the fluid level required
4. Capitor
5. Pump body and motorcasing in stainless steel AISI 304
6. Sealing system: Outer mechanical seal in silicon carbide. Inner lip seal in nitrile rubber
7. Shaft in stainless steel AISI 304
8. Delivery port from 2" (50 mm) except DX(V) 35-5 with 1" 1/2 ports (35 mm)
9. Impeller, vortex or channel type, in stainless steel AISI 304 (or fibreglass-reinforced nylon in the DXV 35-5)
  - all elastomers in nitrile rubber (NBR)
  - all screws and washers in stainless steel AISI 304

### Motor rating

Pump type	Power	Input current A	
		220-240 V	380-415 V
<b>Three phase</b>	<b>kW</b>		
DX(V) 35-5	0.55	2.15	1.3
DX(V) 50-7	0.75	3.5	2.0
DX(V) 50-11	1.1	4.8	2.8
DX(V) 50-15	1.5	6.2	3.6

Pump type	Power	Capacitor		Input current A
		µF	V	
<b>Single phase</b>	<b>kW</b>			<b>220-240 V</b>
DX(V) 35-5 M	0.55	16	450	3.3
DX(V) 50-7 M	0.75	22	450	5.1
DX(V) 50-11 M	1.1	30	450	7.1

### Performance curves

#### DX

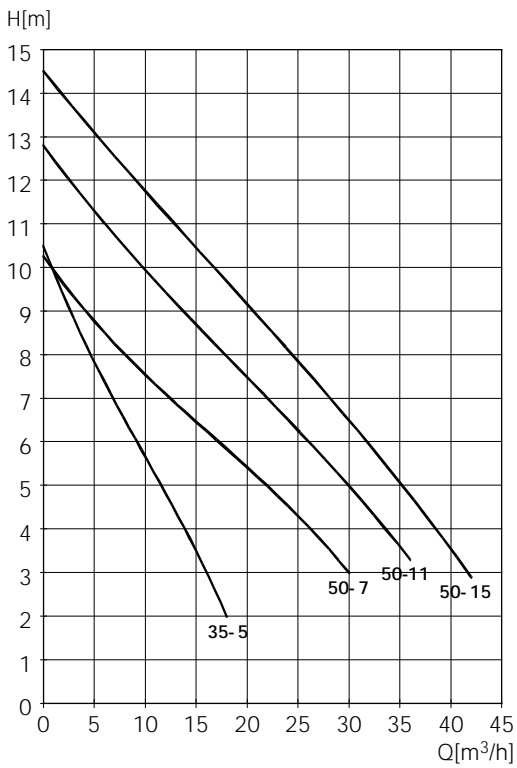

#### DXV

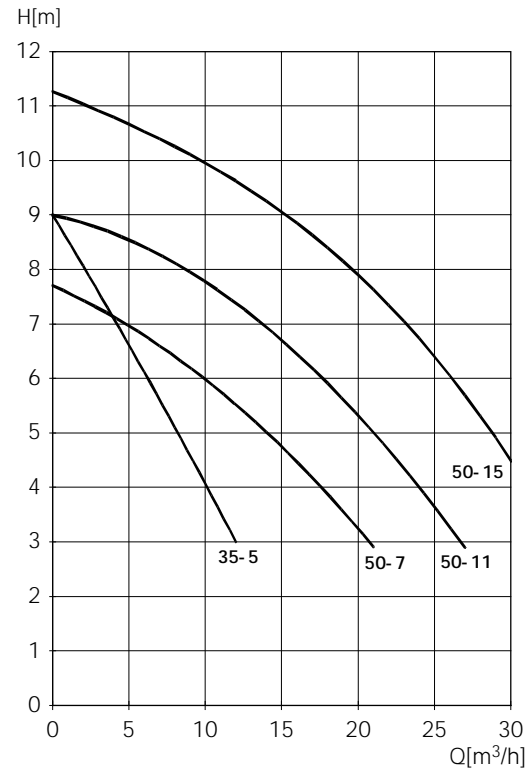

### Dimensions and weight

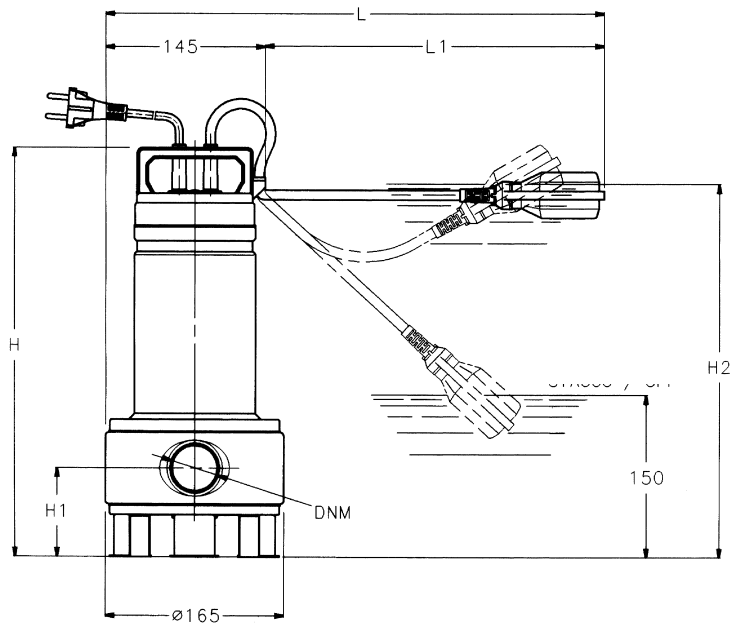

Pump type	Dimensions in mm						DNM	Weight kg
	H	H1	H2	L	L1	L2		
DX(V) 35-5	386	88				193	RP 1½"	8.5
DX(V) 50-7	433	111				198	RP 2"	11.5
DX(V) 50-11	463	111				198	RP 2"	13.5
DX(V) 50-15	463	111				198	RP 2"	14.5
DX(V) 35-5 M	386	88	370	420	275	193	RP 1½"	10
DX(V) 50-7 M	463	111	415	495	350	198	RP 2"	13.5
DX(V) 50-11 M	463	111	415	495	350	198	RP 2"	15