

50 HZ



Ready

DURABLE, LIGHTWEIGHT AND EASILY SERVICEABLE SUBMERSIBLE PUMPS.

FLYGT
a xylem brand

Multipurpose. Multiple use. Made for the duration.

Whether it's for construction or industrial sites, manholes or emergency situations, you'll be ready for on-the-spot dewatering – time and time again.

The smallest of the Flygt electric submersible dewatering pumps, the Ready series is built to withstand tough jobsite use, removing contaminated water and water containing sand and gravel, with ease. This is not your average throwaway pump. Engineered for repeated use, year after year, Ready pumps are the smart choice to reduce environmental impact.





Compact, lightweight and easy to carry.

Built with a compact motor and lightweight materials, Ready pumps are easy to carry, install and service. These pumps go where other pumps do not fit and can be stored easily in service vehicles for quick response to flooding or clean-up.

Made for wear and tear

The cast aluminum outer casing, stator housing and polyurethane hydraulic parts make Ready pumps durable for tough jobsite environments. They deliver professional level performance and higher wear resistance in a compact size.

Highly serviceable

Ready is designed with a removable top that allows easy access for cable changes and component replacements. The hydraulic end is made for simple and quick replacement of wear parts and seals.



Ergonomic handle:
Comfortable design for easy and safe lifting, carrying and handling of the pump.

Removable top: Provides easy access to junction box for wiring and component replacement.

Auto-cut: Automatically protects the motor from overheating and damage, reducing downtime and saving on repairs.

Motor: Robust and light-weight squirrel cage induction motor for reliable performance.

Rubber strainer: Impact protection in case the pump is dropped or installed roughly.

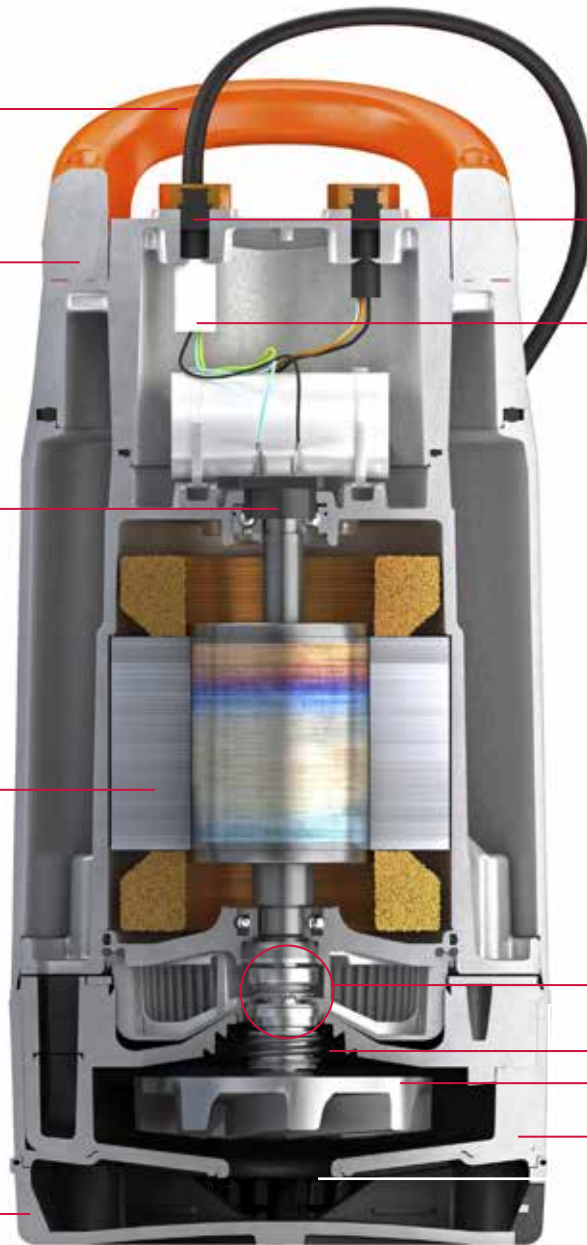

Adjustable discharge:
Vertical and horizontal discharge options for easy hose connection.

Cable strain relief: Limits stress on cable connection enabling a longer cable life.

Cable with water-cut:
Protects electrical components by stopping water from entering the pump through damaged cables.

Double mechanical seal:
Two sets of mechanical shaft seals that work independently. More reliable than single or lipseal - double the security.

Spin-out™: Protects seal by expelling abrasive particles from the seal chamber, ensuring longer life.

Polyurethane hydraulic parts (impeller and diffuser): Provides high wear resistance and allows for passage of abrasive materials.

Polyurethane pump housing:
Provides high wear resistance and allows for passage of abrasive materials.

Vortex impeller: The throughlet can handle larger particles which will reduce the risk of clogging.

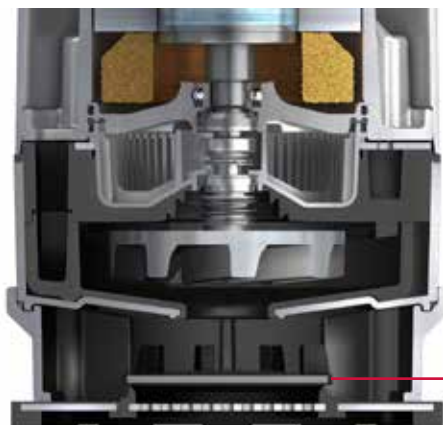

Non return valve:
For minimised back flush.

Low suction bottom:
Designed to pump more or less dry around the pump.

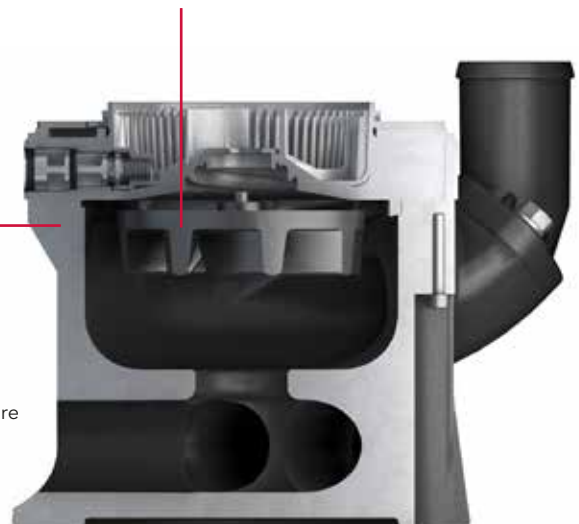

Ready 4L

Ready 8S

DOWN TO THE FLOOR PUMPING

with Low Suction Ready 4L

NEW!

The latest addition to the Ready fleet is the all new 4L, a low suction pump designed to pump more or less dry around the pump. Ideal for flood cleaning operations, water filled basements and emptying tanks.



Pump away water down to 1-2 mm. When standing on a flat floor: Hmax: 10,5 m and Qmax: 3,2 l/s.



Increased performance: Raise the pump to open up inlet and increase the performance to almost match Ready 4.



Start pumping at extremely low levels: Simply prime the pump by adding water to get started.

Minimised back flush: A special Ready 4L feature is the built in non-return valve to prevent so called back-flush. The water is kept inside when the pump is turned off or lifted up. When the pump is started, a valve disc opens up and lets the water pass through until the water is gone, or until you turn off the pump. When the valve disc closes, it goes down and seal against the lip-ring on low suction base and prevent water to flush out.

Performance & technical data

Flygt Ready pumps handle flows up to 6 l/s, heads to 14 m, and solids up to 38 mm in diameter. Available with power ratings from 0.4 to 0.9 kW, these portable drainage pumps are lightweight and engineered for professional use.

4&8



Weighing only 12 and 14.5 kilos respectively, Ready 4 and 8 are designed for dewatering of construction sites, flood cleaning operations and similar applications. They can handle abrasive and corrosive liquids in the range of pH 5-8 and particle sizes up to 5 mm.

4L



This is as low as it gets. Ready 4L is the low suction pump that can handle water levels down to 1-2 mm. For a completely dry result just bring out the mop.

8S



The Ready 8S is a solids-handling pump designed for contaminated water and water containing sand, gravel and debris with particle sizes up to 38 mm.

Power ratings and sizes (50 Hz)

Model	Ready 4	Ready 4L	Ready 8	Ready 8S
Product code	2004.212	2004.230	2008.212	2008.281
Rating [kW]	0.42	0.42	0.75	0.9
Voltage [V/phase]	230, 1~	230, 1~	230, 1~	230, 1~
Rated current [A]	2.7	2.7	4.2	5.2
Weight [kg]	12	13	14.5	17
Height [mm]	438	464	438	512
Width [mm]	184	188	184	262
Discharge Ø [in]	2"	2"	2"	2"
Throughlet [mm]	-	1.5 x 15	-	38
Strainer hole [mm]	11x5	-	11x5	-
Warm liquid, 70°C	No	No	No	No

For additional specifications, see product technical documentation. With reservation for changes.

Performance curve

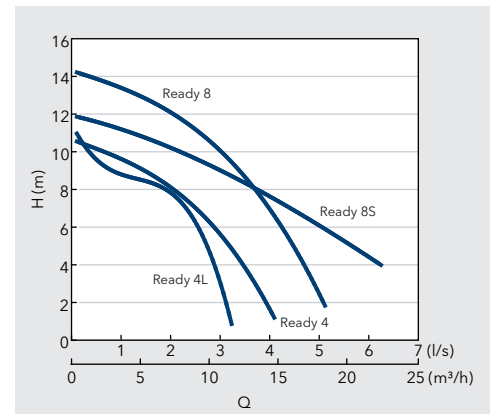

Spare Part Kits

Xylem offers ready-to-buy, easy-to-use spare part kits for the Ready pumps. Each kit contains all the parts that need to be changed due to normal wear during a particular type of repair, as well as an easy-to-follow instruction sheet.

- Complete set of parts for the task at hand
- Simplified handling
- Time savings
- Cost-efficient repairs
- Fast delivery
- High-quality parts
- Easy-to-follow instruction sheet



Diffusor kit including diffuser, hexagon head screws, plain washers, barrel nuts and a mounting instruction.



Seal kit including inner mechanical seal, outer seal kit, retaining ring and a mounting instruction.



Impeller kit including torque flow impeller, plain washer, hexagon socket head screw and a mounting instruction.



Low Suction Kit for Ready 4L

- Low Suction Cuff
- Low Suction Strainer
- Valve
- Barrell Nut
- Hex. Socket HD Screw
- O-ring

The following Ready kit types are also available:

Ball bearing kit, Outer seal kit, Stator housing kit, O-ring kit, Level regulator kit, Cable kit, Discharge connection kit.



Options & Accessories

Enhance the performance of Ready pumps by selecting options and accessories specially designed to simplify pump installation and operation.



Low suction cuff



Hose



Ready Cable



Level regulator



Raft



Quick Coupling Storz

Ready	4	4L	8	8S
Options				
Discharge connections:				
- Hose	●	●	●	●
- Thread ISO G2A	●	●	●	●
- Thread NPSM 2-11 ½	●	●	●	●
- Quick coupling Storz	●	●	●	●
Low suction cuff	●	○	●	○
Level regulator	●	●	●	●
Accessories				
Hose & couplings	●	●	●	●
Raft 25	●	○	●	○

● Available ○ Not available



Nobody does dewatering better

Whatever the dewatering challenge we have the solution for you. Sludge, slurry, big pumps, small pumps, electrical or diesel driven, corrosive abrasive particles or high pH levels, we have the pump that matches your requirements with a reliability and performance second to none. From the legendary Flygt Bibo to the light-weight Ready, the sturdy Flygt 5000 to the independently-powered Godwin there is no other company that covers the full spectrum of dewatering needs like Xylem. We've got your back!



Xylem TotalCare

Xylem TotalCare is a comprehensive, integrated portfolio of services designed to ensure that your water and wastewater equipment keeps running at its best. Our team of knowledgeable and highly skilled technicians are experts in drainage and slurry applications. We take pride in our ability to help customers overcome challenges and optimize operations by providing the right solution every time.

Our service network spans 150 countries and chances are we have a workshop close to your operations that can support you with application engineering, maintenance, pump repair, spare parts, turnkey project management, and more. We look forward to hearing from you.

Find out more about TotalCare services at xylem.com/totalcare

xylem
Let's Solve Water

Xylem ['zīləm]

- 1) The tissue in plants that brings water upward from the roots
- 2) A leading global water technology company

We're a global team unified in a common purpose: creating innovative solutions to meet our world's water needs. Developing new technologies that will improve the way water is used, conserved, and re-used in the future is central to our work. We move, treat, analyze, and return water to the environment, and we help people use water efficiently, in their homes, buildings, factories and farms. In more than 150 countries, we have strong, long-standing relationships with customers who know us for our powerful combination of leading product brands and applications expertise, backed by a legacy of innovation.

For more information on how Xylem can help you, go to xyleminc.com.



Flygt is a brand of Xylem. For the latest version of this document and more information about Flygt products visit www.flygt.com